

115

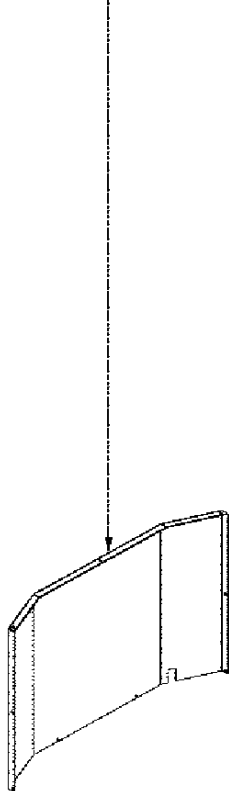

116

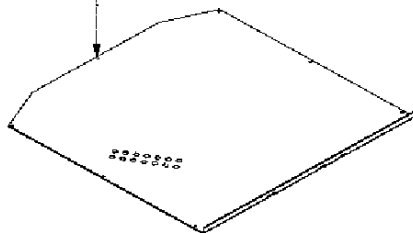

111



110

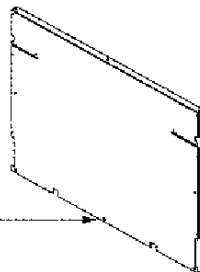

138

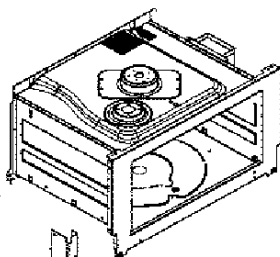

166



160



164



162

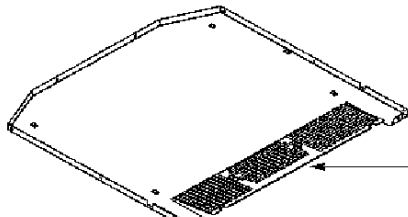

123

280

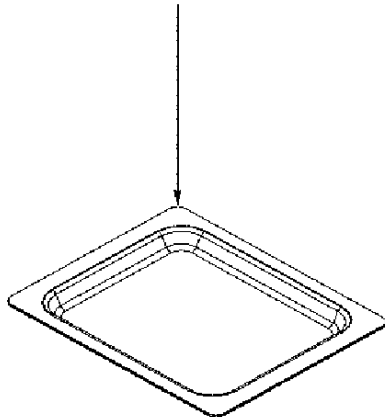

293

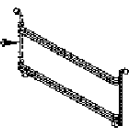

285



291



282

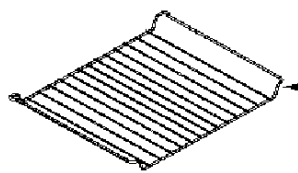

352

335

356

320

355

366

368

367

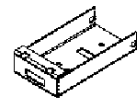
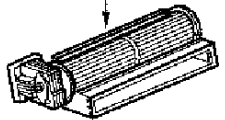
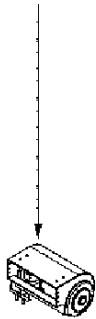

365

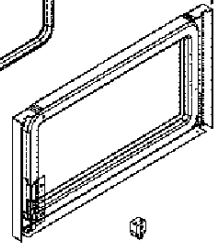
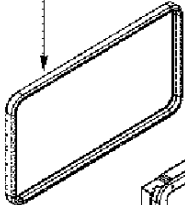

361



305

341

340

345

346

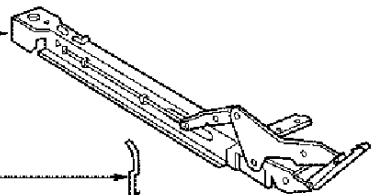
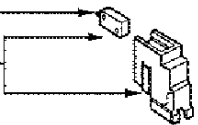

363

303

302

316

310

336

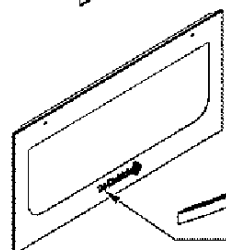

336

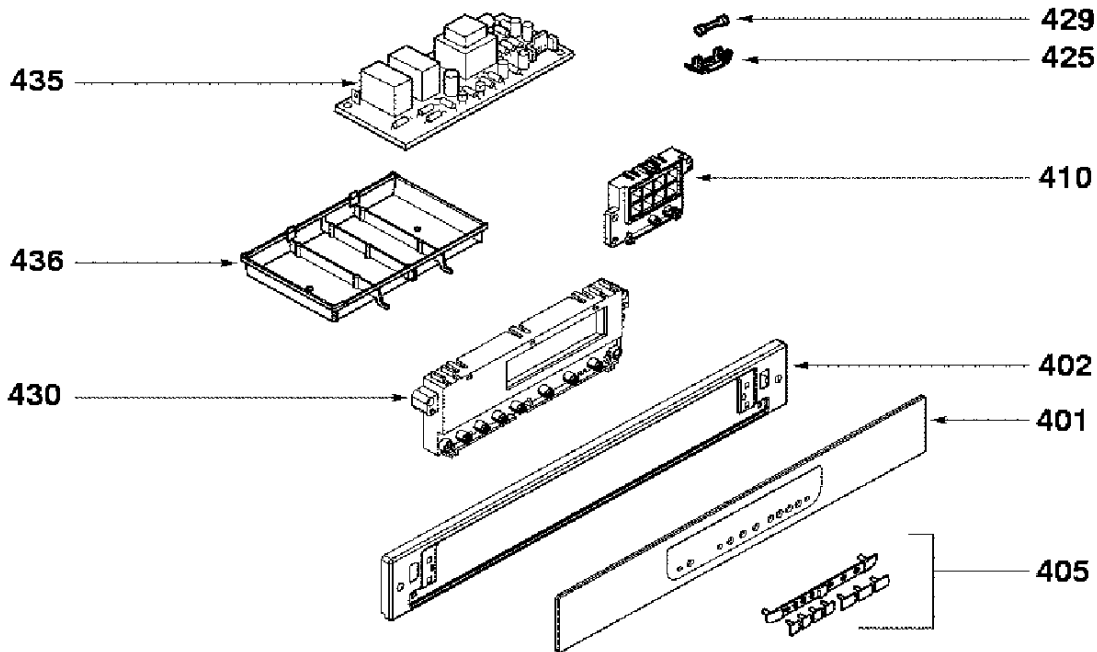

**585**

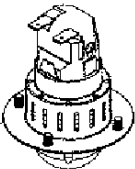

**584**



**586**

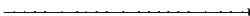

**594**



**592**



**593**



