

350

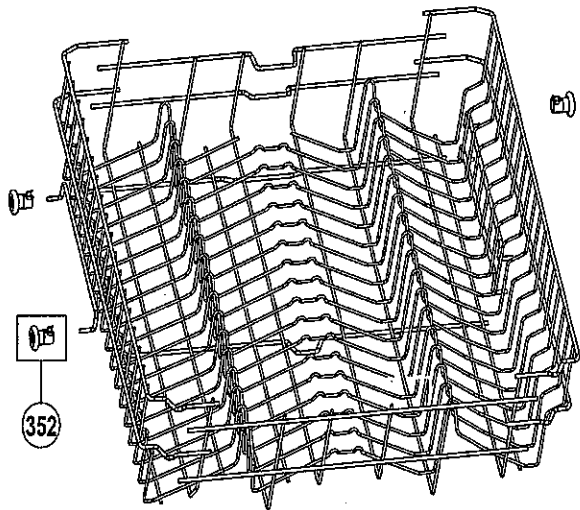

352

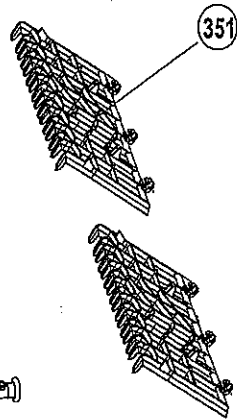

351

156

155

154

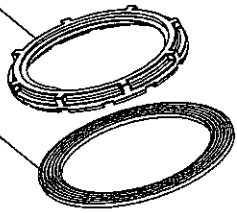

148

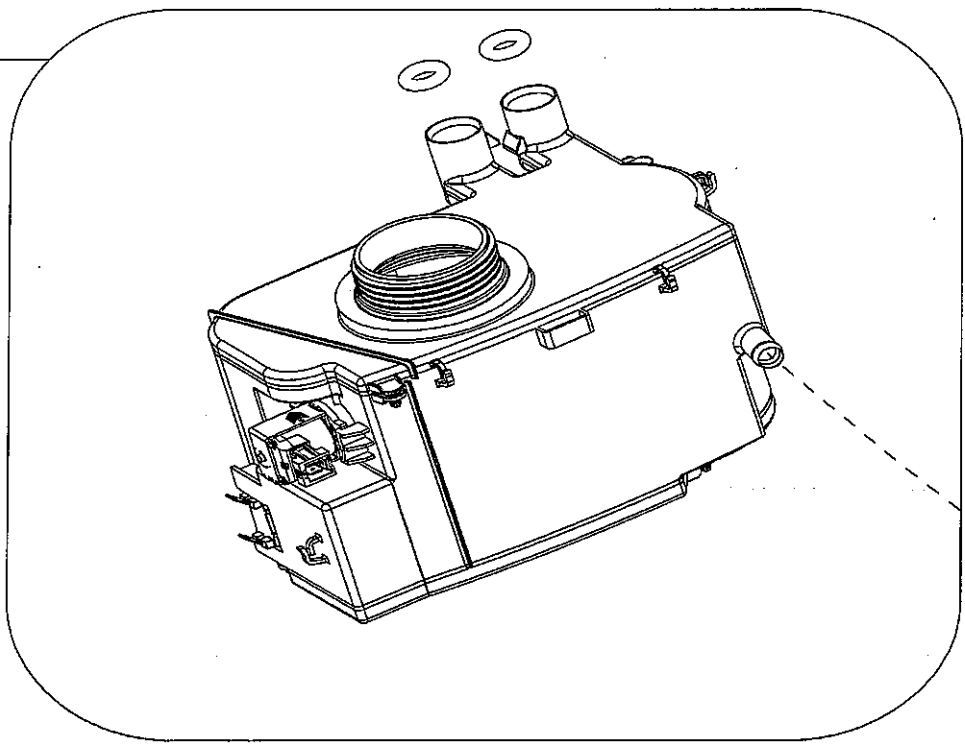

152

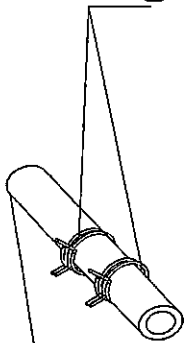

153





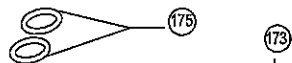
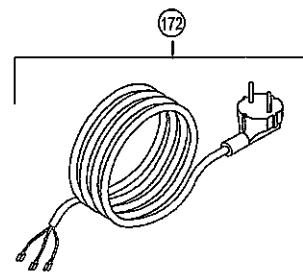
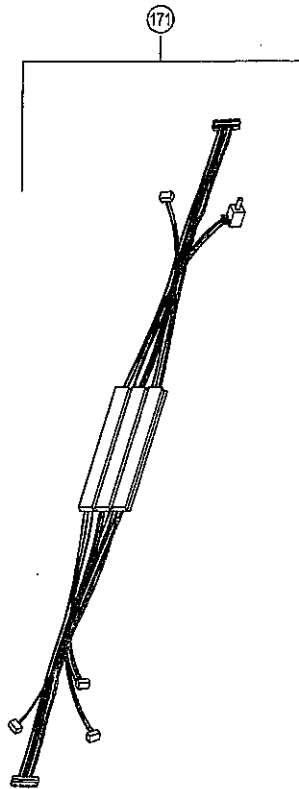
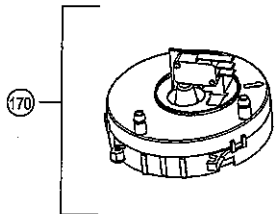

173

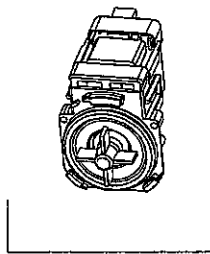
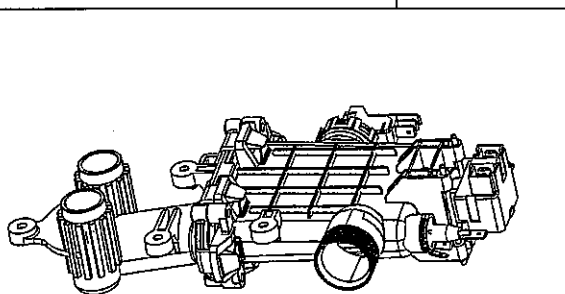

176

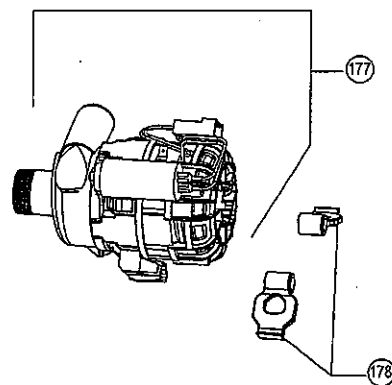

177

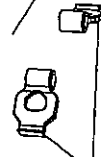

178

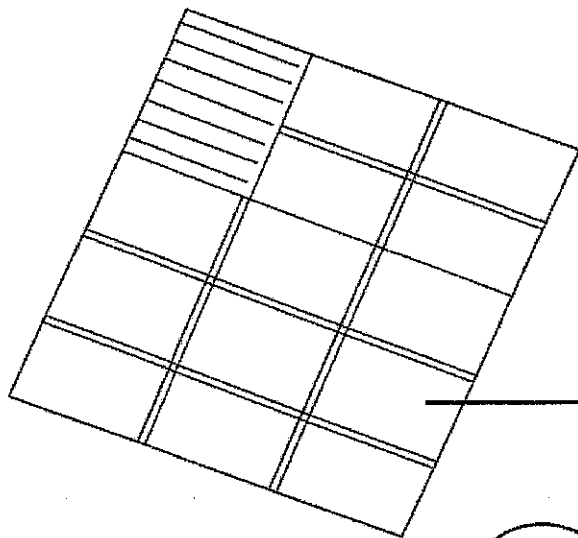

500

501

502



503



504

505



506



507



508

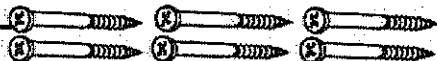

509



510



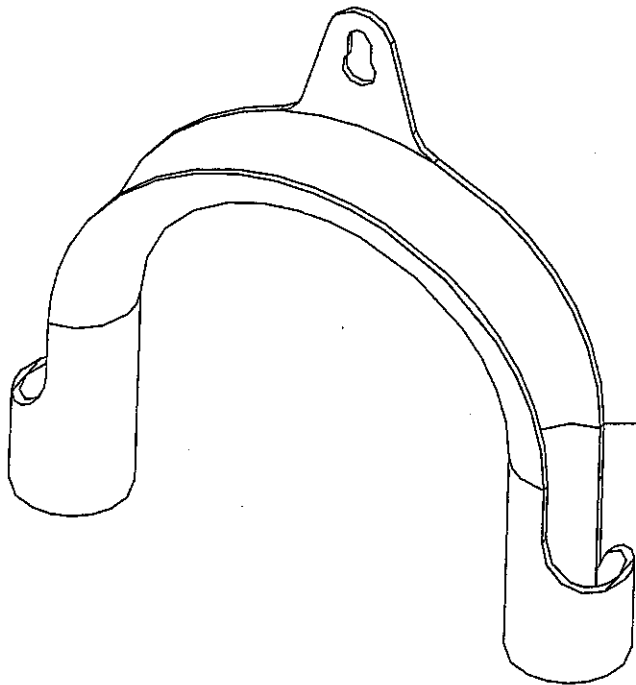

512